

# Vibration and Sound

---

**Mechanical oscillation, wave propagation, and sound fields**

**Lorenz Schwarz**

Karlsruhe University of Arts and Design (HfG)

Winter Semester 2024/25

[Course info](#)

[← Chapters](#) · [Download PDF ↓](#)

*For iPhone/iPad users, the PDF download is recommended.*

# VIBRATION AND SOUND

---

Lorenz Schwarz · HfG Karlsruhe · CC BY 4.0

# The physical and perceptual nature of sound

---

A complex relationship between:

1. Physical disturbance in a medium and transfer of energy
2. Psycho-physical perception and sensory experience of the physical stimuli

Lorenz Schwarz · HfG Karlsruhe · CC BY 4.0

# Wheel of acoustics

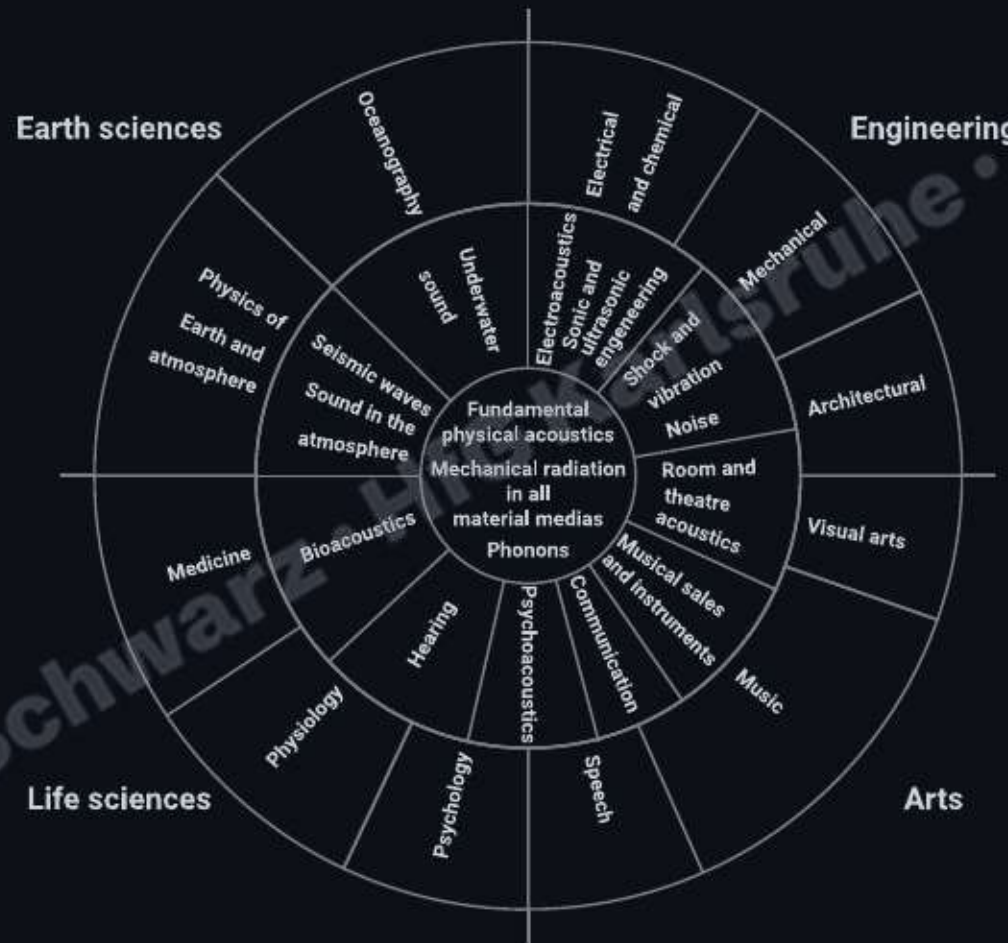

(Beyer 300)

# Sound (physics)

---

Etymology: Derived from Latin *sonare* (to sound)

Pressure or density variations in an elastic medium (e.g., air):

- particle displacement (e.g., air molecules)
- particle velocity

Lorenz Schwarz · HfG Karlsruhe · CC BY 4.0

# Elasticity and inertia

---

- **Elasticity:** The property of a material or medium that enables it to return to its original shape or equilibrium after being deformed, once the applied force is removed.
- **Inertia:** An object in motion remains in motion, and an object at rest stays at rest, unless acted upon by an external force (Newton's First Law of Motion).

Lorenz Schwarz · HfG Karlsruhe · CC BY 4.0

# Vibration and sound

---

Mechanical vibration is capable of producing sound, e.g.:

- strings (chordophones)
- membranes (membranophones)
- plates (struck idiophones)

Lorenz Schwarz · HfG Karlsruhe · CC BY 4.0

# Oscillation

---

A process that returns to the same state after repeating periods:

- periodic vibration or cyclical process
- number of occurrences of a repeating event per second
- measured in hertz (Hz)

Lorenz Schwarz · HfG Karlsruhe · CC BY 4.0

# Case study: spring-mass system

Vertical back and forth movement of a mass on a spring:

- Newton's Second Law:  $F = m \frac{dv}{dt} = ma$
- Hooke's Law (restoring force):  $F = -kx$

constant:

- $k$  spring constant
- $m$  mass

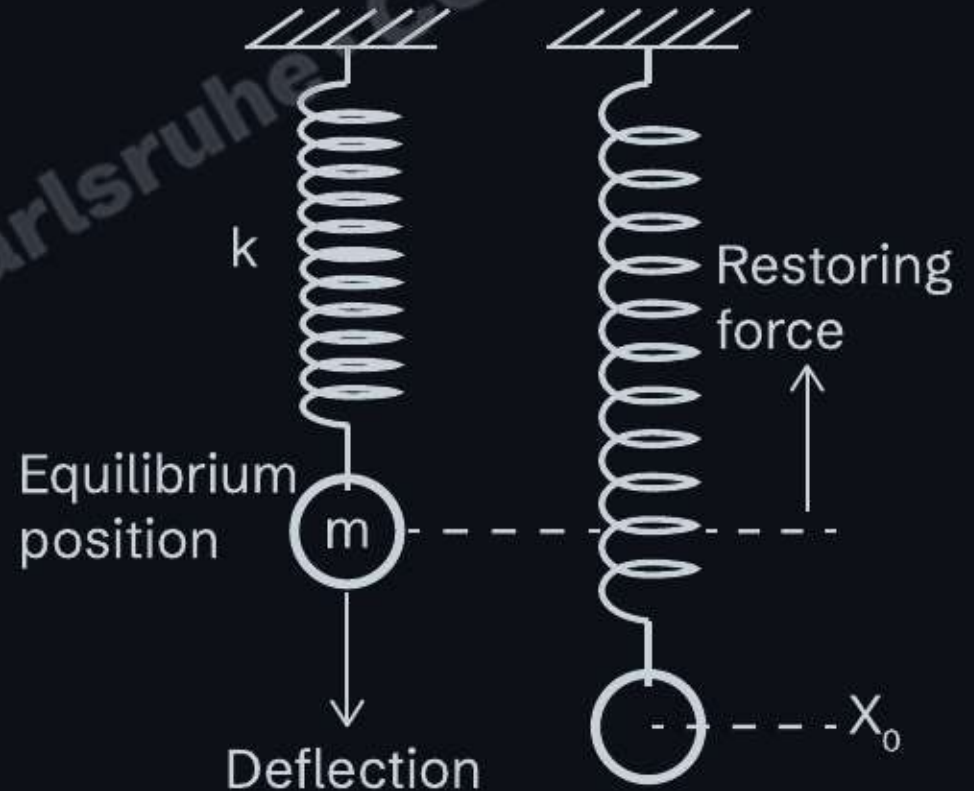

## Simple harmonic motion of a spring-mass system

- Newton's Second Law:  $F = ma$
- Hooke's Law (restoring force):  $F = -kx$

$$ma = -kx$$

variables:

- $a$  acceleration
- $x$  displacement from equilibrium

Lorenz Schwarz · HfG Karlsruhe · CC BY 4.0

## Acceleration

$a = \frac{dv}{dt}$  first derivative of the velocity with respect to time

or

$a = \frac{d^2x}{dt^2}$  second derivative of the position with respect to time

$$\frac{d^2x}{dt^2} = -\frac{k}{m}x$$

(second derivative of the function is the function)

## Sine and cosine

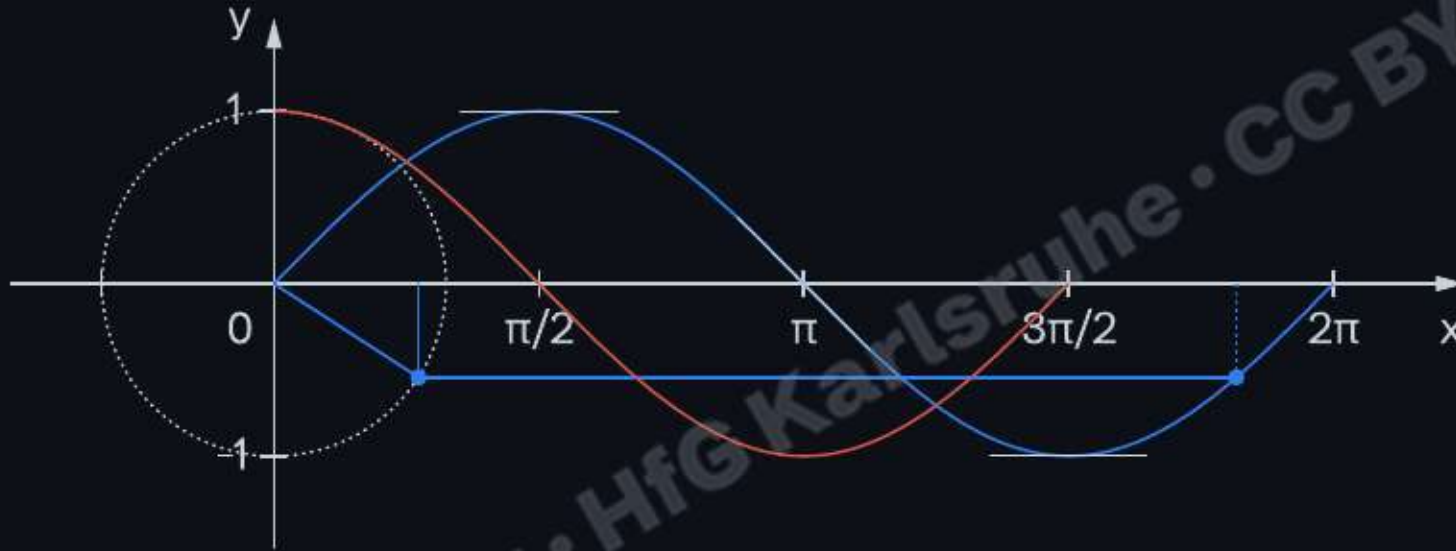

The gradient of the tangent equals the derivative of the function at the point where the curve and tangent line meet.

[view in graphing calculator](#)

## Solving the differential equation

- first derivative of  $\sin(\omega t)$  is  $\omega \cos(\omega t)$
- and second derivative of  $\sin(\omega t) \rightarrow -\omega^2 \sin(\omega t)$

$$-\omega^2 \sin(\omega t) = -\frac{k}{m} \sin(\omega t)$$

$$\omega = \sqrt{\frac{k}{m}}$$

$$2\pi f = \sqrt{\frac{k}{m}}$$

$$f = \frac{1}{2\pi} \sqrt{\frac{k}{m}}$$

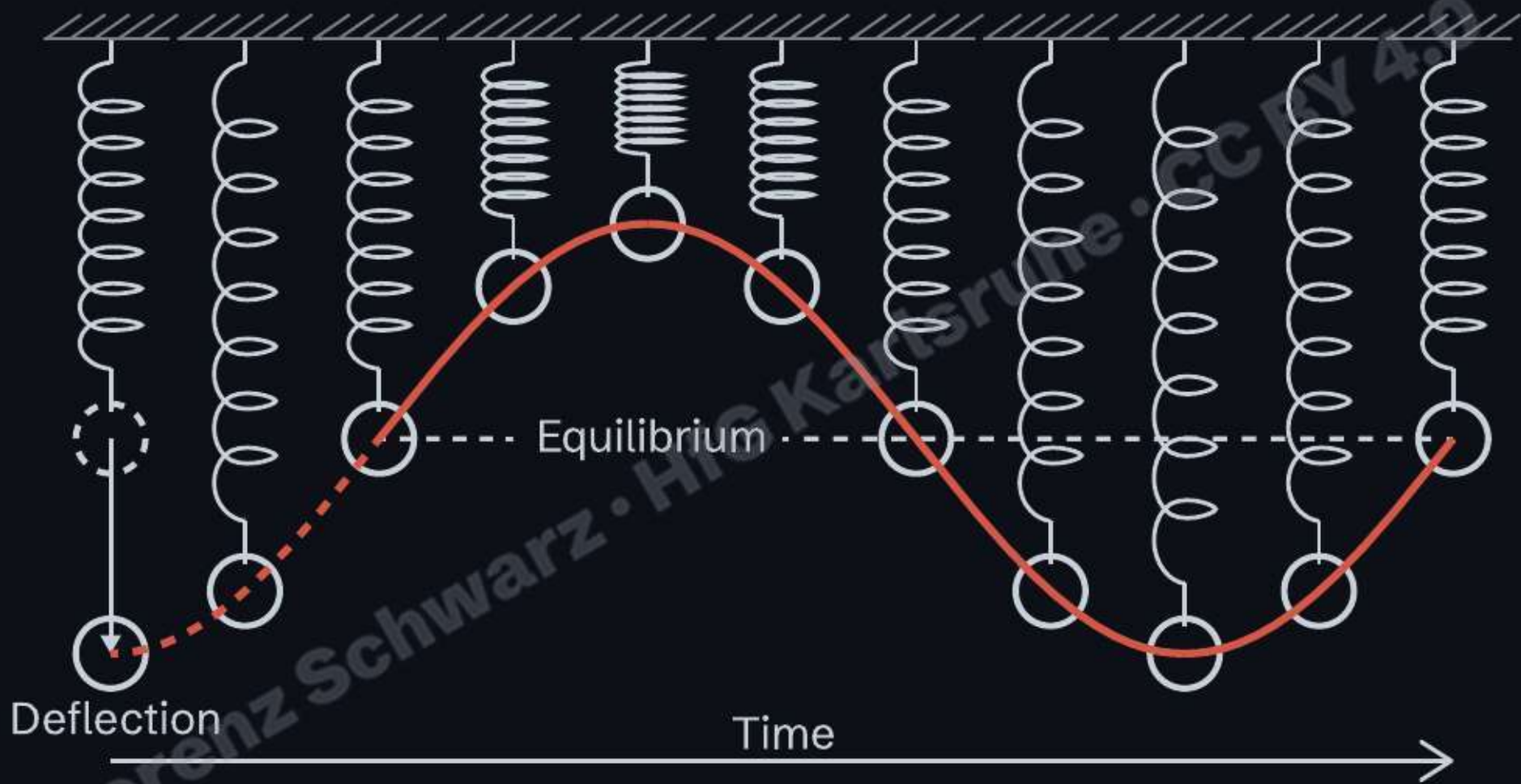

Simple harmonic motion of a mass-spring system

# Oscillation of a mass-spring system

---

The mathematics confirms what we observe: a mass on a spring oscillates sinusoidally. The sine wave is the fundamental pattern underlying all sound.

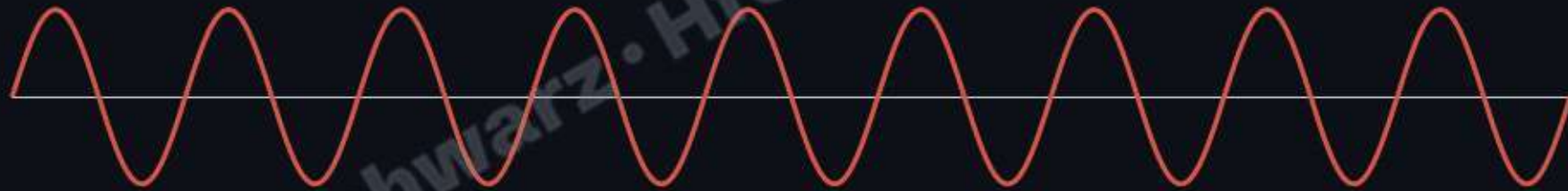

▶ Sine wave 400 Hz

# Sine wave

---

Medieval Latin *sinus*, from Latin, curve

Displacement plotted against time describes a curved and symmetrical rise and fall with no abrupt changes:

- simplest periodic function
- describing periodic phenomena (vibration)
- "pure tone", because it has no other constituent frequencies.

Lorenz Schwarz · HfG Karlsruhe · CC BY 4.0

# Sine wave function

---

The time dependence of a harmonic motion is described by a sine (or cosine) oscillation whose argument is a linear function of time:

$$x(t) = A \sin(2\pi ft + \varphi) = A \sin(\omega t + \varphi)$$

- $A$  peak amplitude (nonnegative)
- $\omega = 2\pi f$  angular frequency (radians/seconds and  $f$  in Hertz)
- $t$  time (seconds)
- $\varphi$  initial phase (radians)

→ *All complex oscillations can be related to the sine wave.*

# Superposition of sine waves

---

When a particle undergoes two or more simultaneous oscillatory movements in the same direction, the result is a combined oscillatory movement, determined by the sum of the individual oscillations.

$$x(t) = A_1 \cos(\omega_1 t) + A_2 \cos(\omega_2 t + \varphi)$$

[view in graphing calculator](#)

1. Two different frequencies, same amplitude

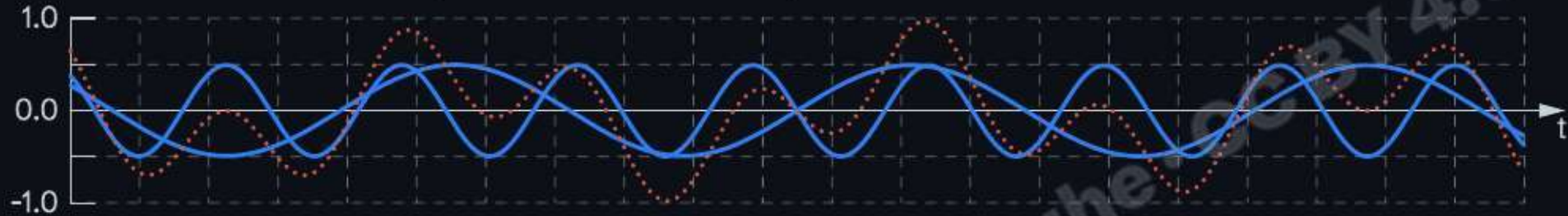

2. Same frequency, opposite phase, one at half amplitude (partial cancellation)

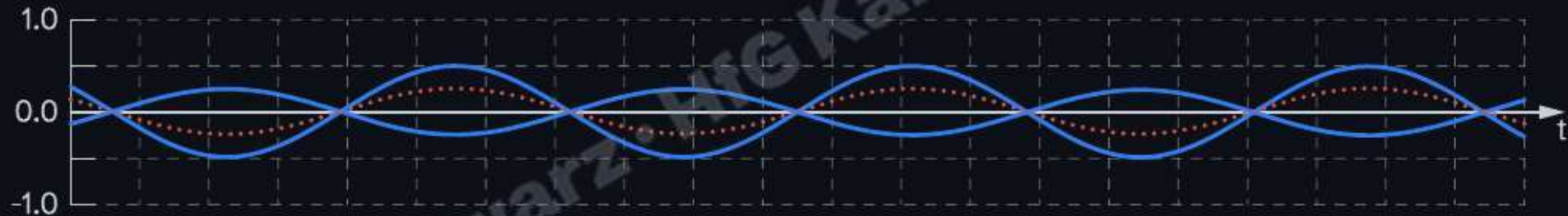

3. Same frequency, same phase, one at half amplitude (constructive)

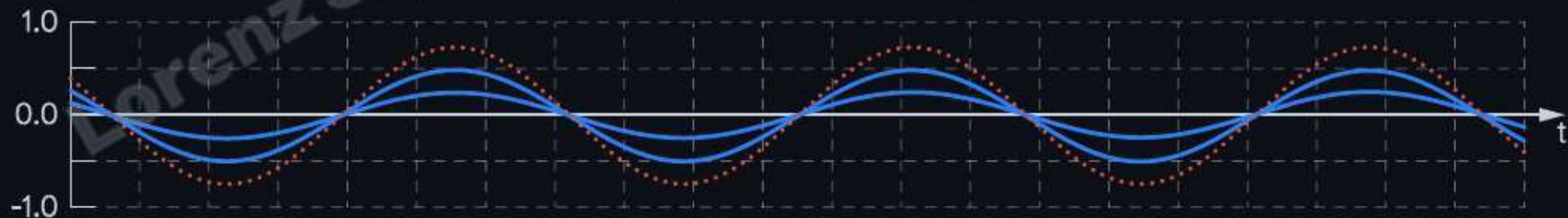

# Oscillation and pressure waves

---

The spring-mass system showed periodic oscillations. Other mechanical systems like strings or speakers create periodic displacements.

In air, this displacement creates:

- Compression (molecules pushed together)
- Rarefaction (molecules spread apart)

→ *These periodic displacements (pressure variations) propagate as sound waves.*

# Back and forth movement of a speaker

The electrical audio signal causes the diaphragm of the speaker to move in an analogous manner:

- When it moves forward, it compresses the air particles in front of it.
- When it moves backward, it creates a region of lower pressure.

→ *These alternating compressions and rarefactions propagate through the air as sound waves.*

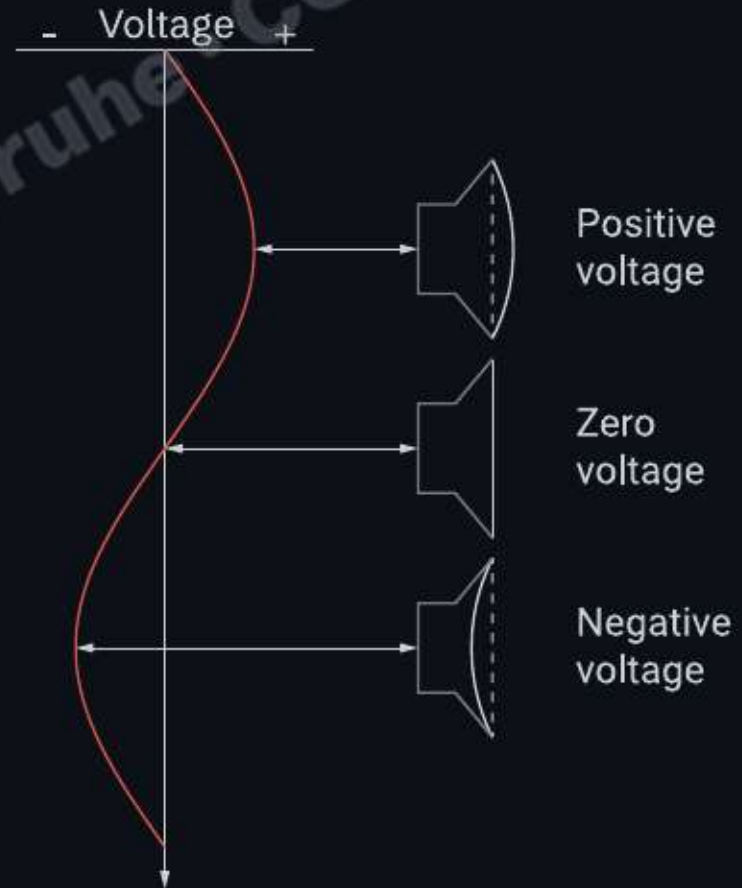

# Sound wave propagation

- Sound is transmitted as longitudinal waves (compression waves) through *gases* and *liquids*.
- It can be transmitted as both longitudinal and transverse waves through *solids*.

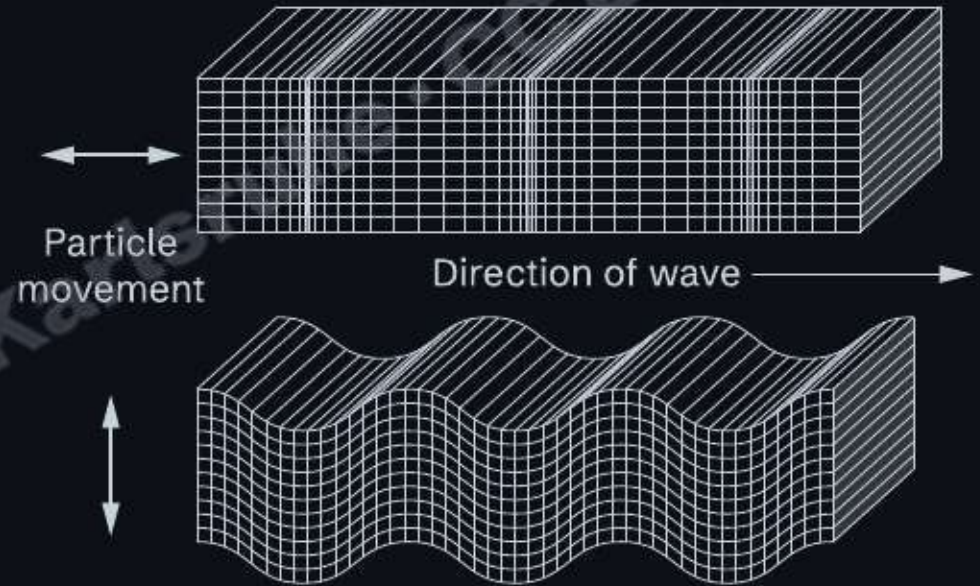

Longitudinal wave (top) and transverse wave (below)

# Transverse and longitudinal waves

---

## Transverse wave:

- particles move perpendicular to the direction of the wave

## Longitudinal wave:

- particles move parallel to the direction of the wave

→ *Longitudinal waves are considered for airborne sound.*

[view in graphing calculator](#)

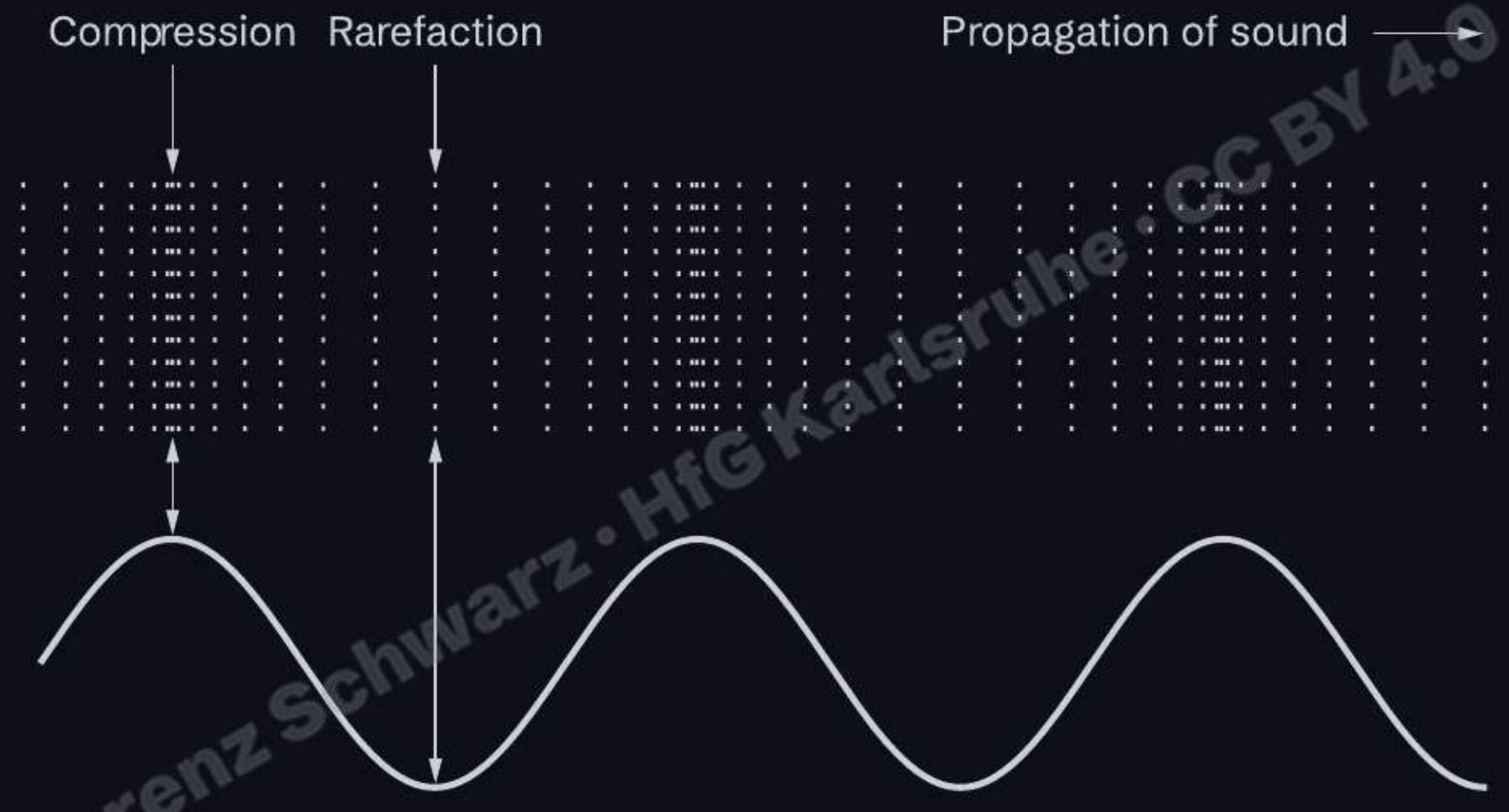

Longitudinal waves are also called compression waves.

# Quantifying sound in space

---

- **Field quantities** (at a point in space):
  - Sound pressure (Pa) — pressure deviation from ambient atmospheric pressure
  - Particle velocity (m/s) — velocity of particle oscillation around equilibrium
- **Energy quantities** (rate of energy transfer):
  - Intensity ( $\text{W/m}^2$ ) — energy flow per unit area
  - Power (W) — total energy radiated from source

→ *Impedance ( $\text{Pa}\cdot\text{s/m}$ ) links pressure and velocity as their ratio.*

## Sound pressure $p$ (sound field quantity)

---

Sound pressure is a property of the sound field at a specific point in space.

It represents variations in air pressure (local compressions and rarefactions) caused by sound waves, typically measured with a microphone, relative to the ambient (static) atmospheric pressure.

$$p_{total} = p_{stat} + p$$

- $p$  = time-varying pressure
- $p_{stat}$  = static pressure
- $p$  in pascals (Pa) = N/m<sup>2</sup>

# Sound pressure level (SPL)

---

Sound pressure level ( $L_p$ ) expresses sound pressure on a logarithmic scale in decibels:

$$L_p = 20 \log_{10} \left( \frac{p}{p_0} \right) \text{ dB SPL}$$

$p$  — measured sound pressure (Pa)

$p_0$  — reference sound pressure

- Reference:  $p_0 = 20 \mu\text{Pa} = 0 \text{ dB SPL}$  (threshold of human hearing at 1 kHz)
- Pain threshold:  $p \approx 20\text{--}60 \text{ Pa} \approx 120\text{--}130 \text{ dB SPL}$

# Particle velocity $v$

---

Particle velocity is the speed of the particles vibrating around their rest position (equilibrium).

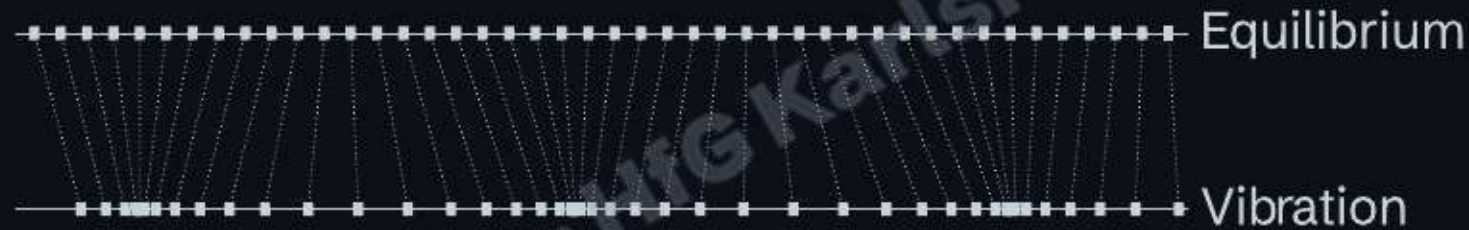

→ *Particle velocity must not be confused with the speed of sound.*

# Sound power

---

Sound is a form of energy:

- Property of the sound source, equal to the total power emitted by that source in all directions.

→ *Sound power is neither dependent on room nor distance*

Lorenz Schwarz · HFG Karlsruhe · CC BY 4.0

# Sound intensity $I$ (sound energy quantity)

---

- Sound intensity is acoustical power per unit area ( $\text{W}/\text{m}^2$ ).
- Sound intensity level (SIL) is its logarithmic representation (dB).

$$L_I = 10 \log_{10} \left( \frac{I}{I_0} \right)$$

Reference sound intensity for the auditory threshold (at 1000Hz):

$$I_0 = 10^{-12} \text{W}/\text{m}^2$$

# Impedance $Z$

---

Acoustic Impedance ( $Z$ ) is the ratio of sound pressure ( $p$ ) to particle velocity ( $v$ ) in a sound wave:

$$Z = \frac{p}{v}$$

Specific Acoustic Impedance ( $Z_0$ ):

For a plane wave or in the far field, the specific acoustic impedance for air at standard temperature and pressure is approximated as:

$$Z_0 \approx 413 \text{ Pa}\cdot\text{s}/\text{m} \approx 413 \frac{\text{kg}}{\text{m}^2 \cdot \text{s}}$$

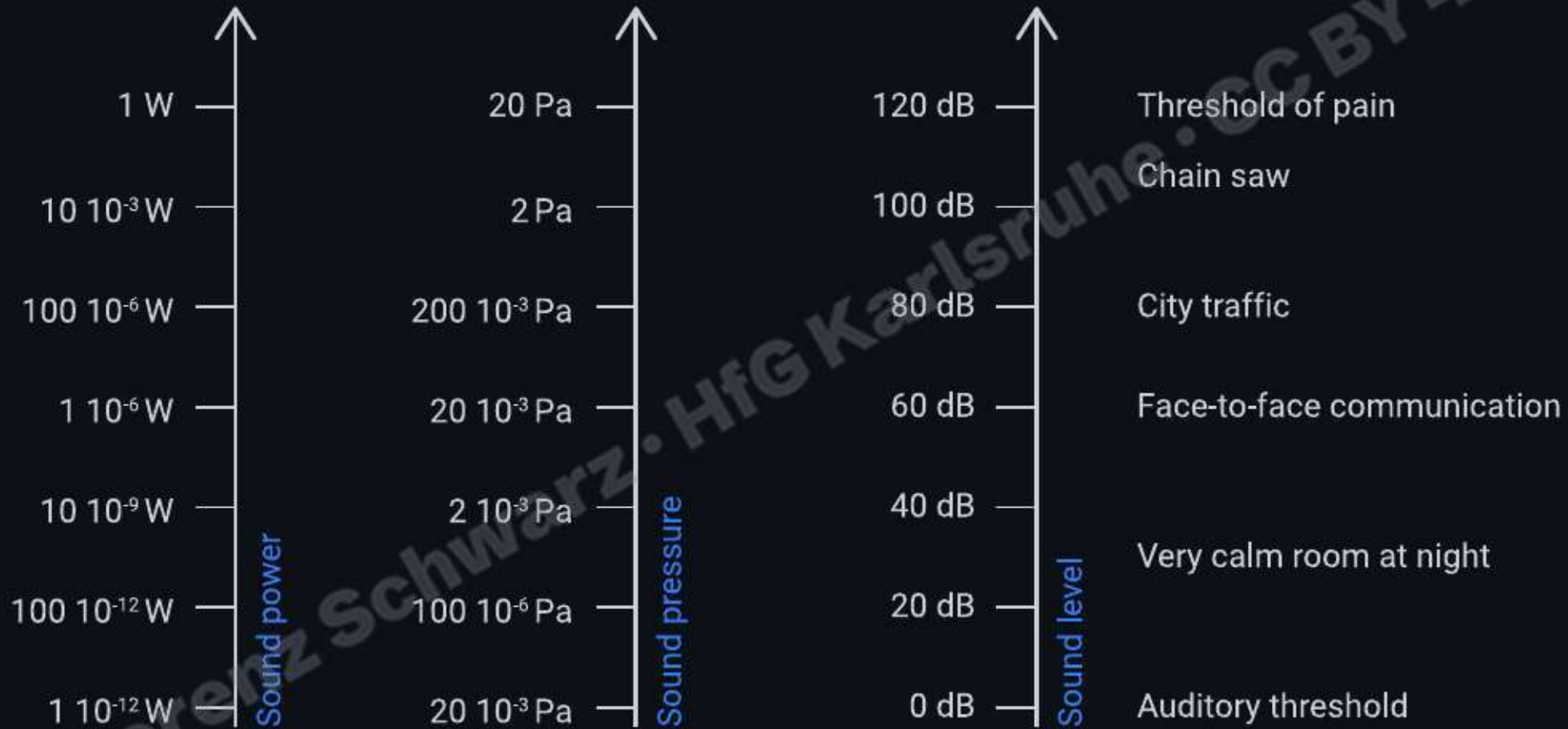

# Sound intensity and sound pressure level

---

Sound pressure level  $L_p$ :

$$L_p = 20 \log_{10} \left( \frac{p}{p_0} \right)$$

Sound intensity level  $L_I$ :

$$L_I = 10 \log_{10} \left( \frac{I}{I_0} \right)$$

→ *Human hearing primarily responds to sound pressure.*

# Spatial behavior

---

An idealized wave that radiates uniformly in all directions from a single point source in 3D space and attenuates with distance:

- The acoustic field variables depend only on the radial coordinate ( $r$ ) and time ( $t$ ).
- Surface area of spherical wavefront:  
 $A = 4\pi r^2$

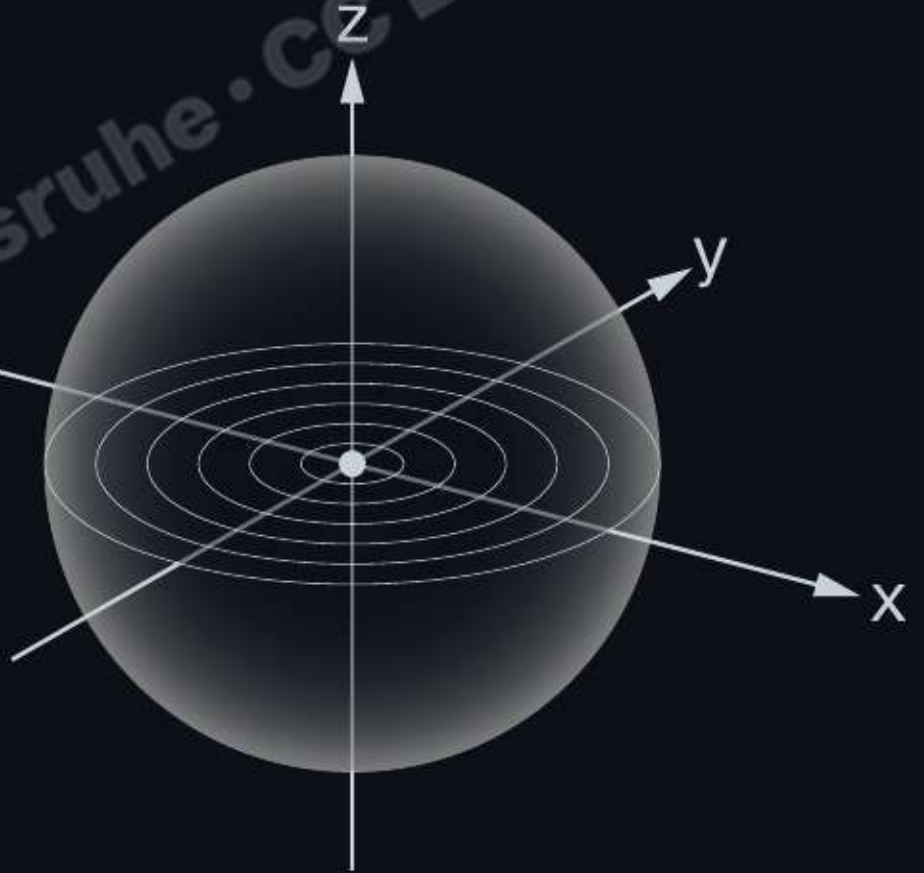

Wave propagation: spherical (short distance), plane (long distance)

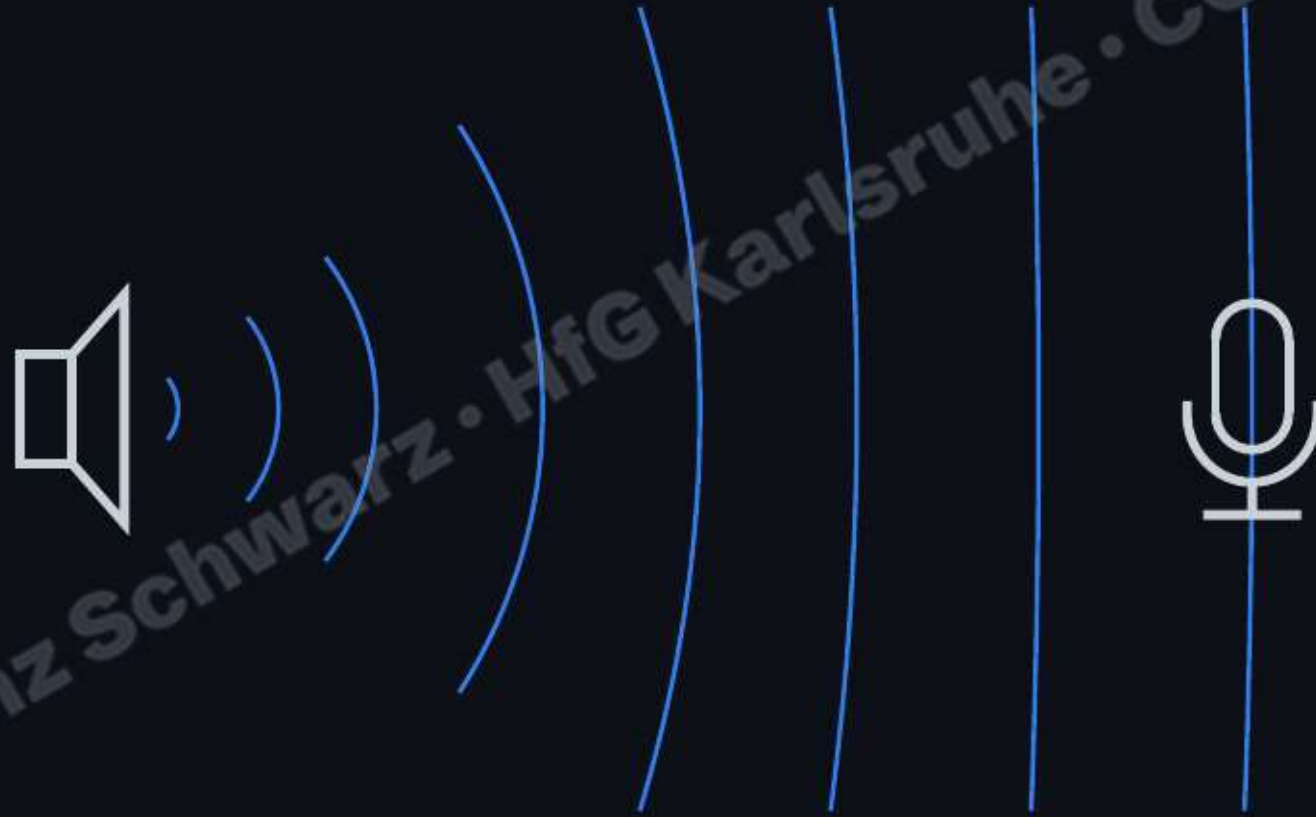

# Acoustic fields and their properties

---

- **Near Field:** A property of the source; the region close to the sound source where the sound pressure and particle velocity are not proportional (non-linear behavior).
- **Far Field:** A property of the source; the region farther from the sound source where sound waves are proportional to the inverse of the distance (linear behavior).
- **Free Field:** A property of the environment; sound propagates without reflections or obstructions.
- **Diffuse Field:** A property of the environment; sound energy is uniformly distributed due to multiple reflections.

# Near and far field

---

- Near field:
  - For point sources, the near field is often approximated as  $r < \lambda$
  - Particle velocity shows strong deviations in the near field.
  - (Where  $\lambda$  = wavelength, distance over which wave repeats)
- Far field:
  - Ratio of sound pressure and particle velocity is constant (in phase).
  - The curvature of the wavefront becomes plane.
  - Sound pressure approximately follows inverse-distance behavior

Lorenz Schwarz | HfG Karlsruhe | CC BY 4.0

# Spherical wave and plane wave

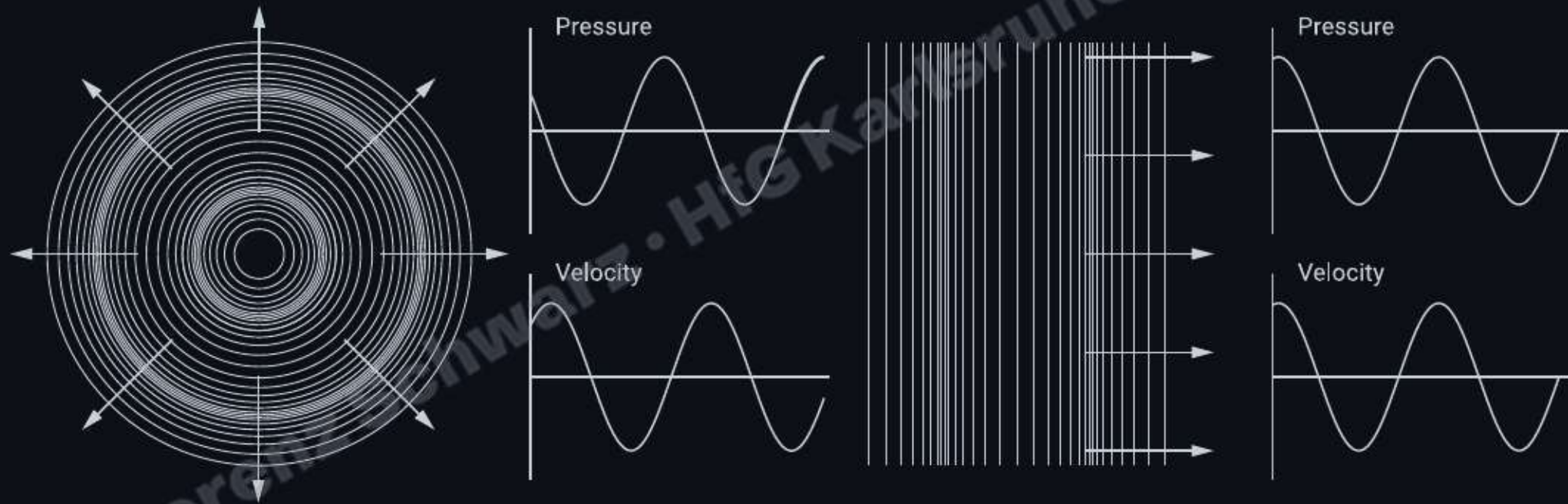

## Free field

---

Region where sound propagates without any interference from reflective surfaces, obstacles, or boundaries, resulting in no reverberation or echo (only direct sound).

→ *Sound is attenuated according to the inverse-square law.*

Lorenz Schwarz · H20 Karlsruhe · CC BY 4.0

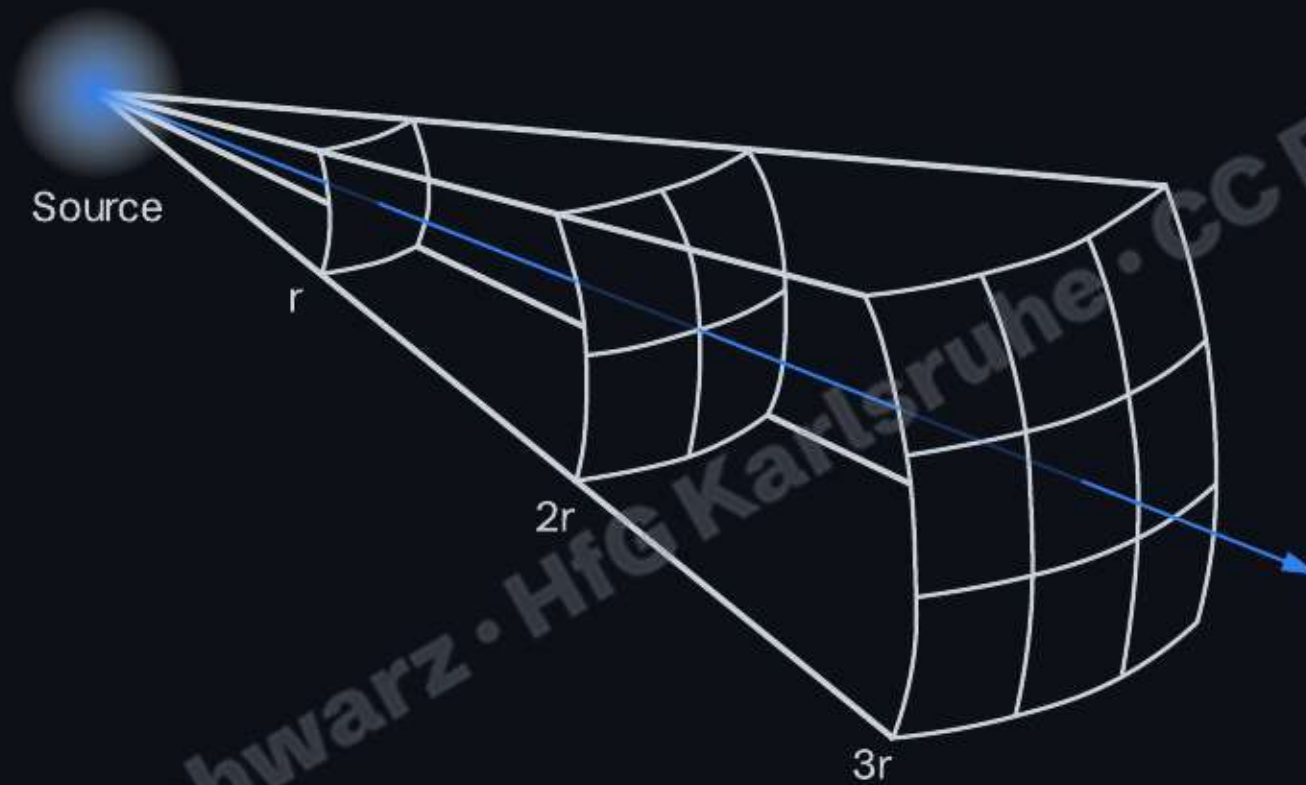

Sound gets weaker as the distance from the sound source increases.  
(Doubling the radius increases the surface area of a spherical wavefront by a factor of four.)

# Sound propagation with distance

---

In free-field conditions, sound level decreases as sound energy spreads over a larger area with distance.

- **Sound intensity:** Doubling distance decreases the level by about 6 dB (intensity level)

$$I \propto \frac{1}{r^2}$$

- **Sound pressure:** Doubling distance decreases the level by about 6 dB SPL

$$p \propto \frac{1}{r}$$

→ *Both intensity level and sound pressure level drop by about 6 dB per distance doubling*

# Line source

---

Cylindrical wavefront radiating from a one-dimensional line source (no vertical dispersion).

$$A_{cylinder} = 2\pi r h$$

Line source attenuates with the inverse of distance ( $1/r$ ), which is a decrease of approximately -3 dB

*Applications:* Sound reinforcement situations (as much energy as possible for the audience, e.g., line arrays)

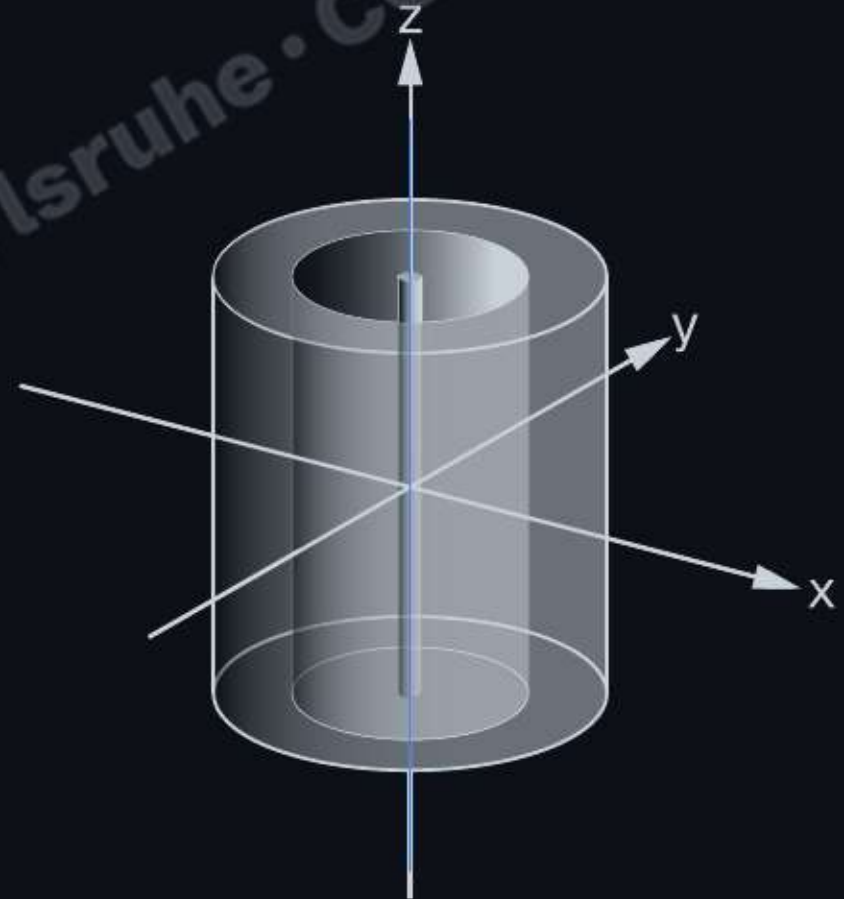

# Copyright and Licensing

---

Original content: © 2025 Lorenz Schwarz

Licensed under [CC BY 4.0](#). Attribution required for all reuse.

Includes: text, diagrams, illustrations, photos, videos, and audio.

**Third-party materials:** Copyright respective owners, educational use.

**Contact:** [lschwarz@hfg-karlsruhe.de](mailto:lschwarz@hfg-karlsruhe.de)

[← Chapters](#)